

FEED AND BIOFUEL  
**FILTER**  
TYPE EFF136WB

Filter of optimum design for efficient dust separation at low operating cost. Filter type EFF-WB is used for removal of dry dust, especially in large quantities, abrasive dust, or dust with low rates of fall. The product range consists of a fully automatic, continuously operating bag filter cleaned by compressed air and built in series, containing from 10 to

260 bags measuring 1,200 to 4,800 mm in length. Filter areas range from 4 to 470 m<sup>2</sup>.

By combining the best, tested components with newly developed cleaning nozzles providing optimum flow, a hitherto unseen low energy consumption has been achieved for compressed air cleaning of filter bags.

The EFF filter is designed as insertable, cased or free-standing filters with cone or scraper bottom.

**COMPRESSED AIR CLEANING OF FILTER BAGS**

Optimum adjustment of cleaning pressure and -cycles to every specific job ensures efficient dust separation, low emissions, and long filter bag life.

**ANDRITZ**

**ENGINEERED SUCCESS**

### FILTER MEDIA

Top-quality filter media selected for specific applications based on requirements relating to service life, emissions, differential pressure, and so on.

### FILTER BAG CHANGING

The filter bags can be changed either from the clean/the dusty air side.

### ACCESSORIES AND SPECIAL EQUIPMENT

- Electronic controls with advanced functions and energy-saving  $\Delta p$  operation
- Emission metering equipment
- Rotary valves
- Manufactured in alternative steel qualities and with alternative surface treatment
- Platforms, ladders, supports, dust containers
- Insulation, heating
- Designed for high temperature and underpressure
- Explosion protection documented acc. to EN14491

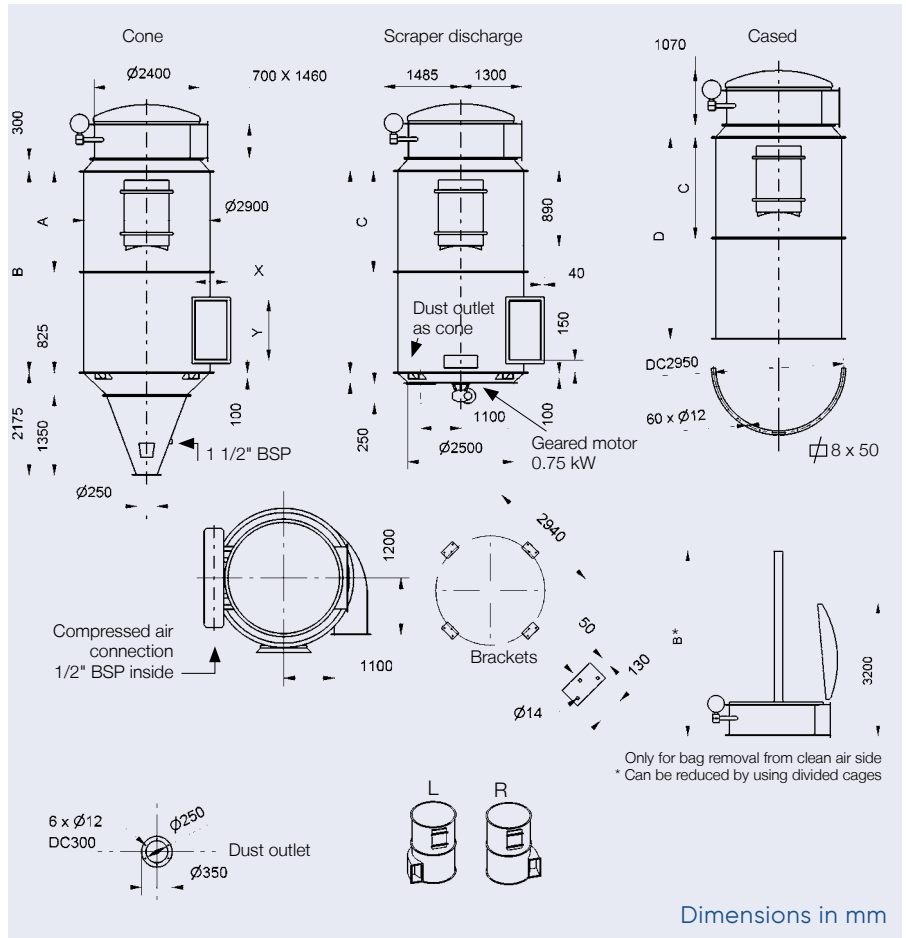

### TECHNICAL DATA

Filter Type	Filter area m <sup>2</sup>	Air Flow m <sup>3</sup> /h	Dimensions mm				Compressed air NI/min *	Weight kg			
			A	B	C	D		Hopper	Total sep.	Cased	Insertable
136/2400	123	22200	2100			2400	260	2375	2600	1840	1125
136/3000	154	27700	1200	2700	1500	3000	260	2650	2875	2115	1215
136/3600	185	33300	1500	3300	1800	3600	260	2875	3100	2340	1310

\* at 180 sec. cycle

### INLET DIMENSIONS

Air volume [m <sup>3</sup> /h]	X	Y
11000 - 20000	460	835
18000 - 33000	585	1085
32000 - 58000	835	1335

**ANDRITZ Feed and Biofuel A/S**  
 andritz-fb.dk@andritz.com  
 p: +45 72 160 300 / andritz.com/ft



All data, information, statements, photographs and graphic illustrations in this leaflet are without any obligation and raise no liabilities to or form part of any sales contracts of ANDRITZ AG or any affiliates for equipment and/or systems referred to herein. © ANDRITZ AG 2021. All rights reserved. No part of this copyrighted work may be reproduced, modified or distributed in any form or by any means, or stored in any database or retrieval system, without the prior written permission of ANDRITZ AG or its affiliates. Due to legal requirements, we must inform you that ANDRITZ AG processes your data for the purposes informing you about the ANDRITZ GROUP and its activities. Find out more details about our data privacy declaration and your rights under the data protection legislation on our website: andritz.com/privacy. ANDRITZ AG, Stattegger Strasse 18, 8045 Graz, Austria.

